

6-FM-4.5

FM Series
Battery For General Use

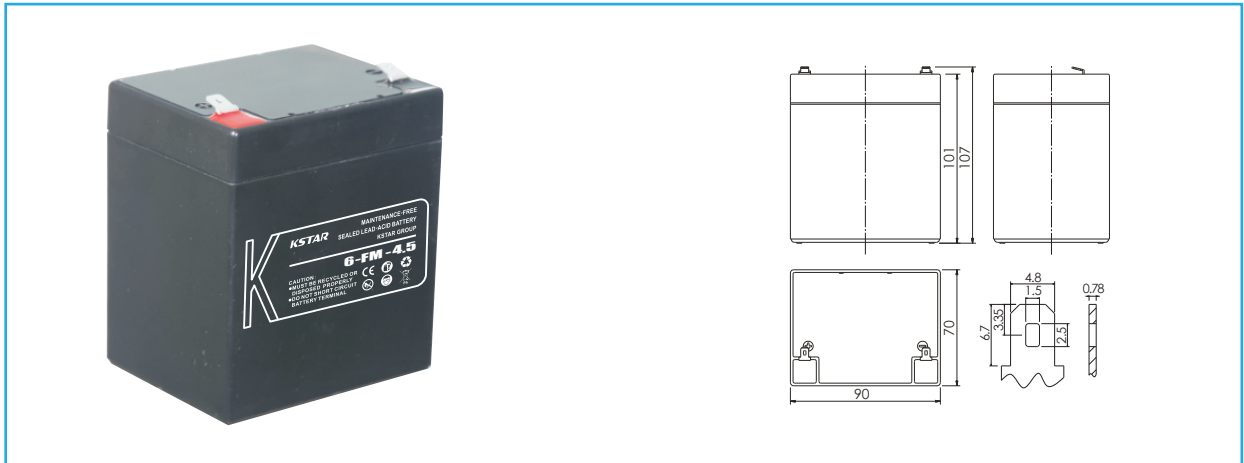

Specifications

Nominal Voltage		12V
Rated Capacity(20 hour rate)		4.5Ah
Dimensions	Total Height (with terminals)	4.21inches(107mm)
	Height	3.97inches(101mm)
	Length	3.54inches(90mm)
	Width	2.76inches(70mm)
Weight		Approx. 3.3pound(1.50kg)

Discharge Curves 77°F (25°C)

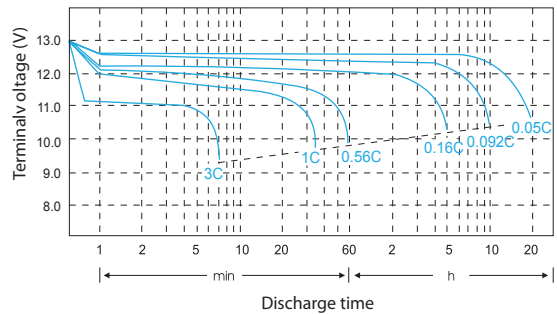

Characteristics

Capacity 77°F(25°C)	20 hour rate (0.23A)	4.5Ah
	10 hour rate (0.42A)	4.2Ah
	5 hour rate (0.72A)	3.6Ah
	1 hour rate (2.7A)	2.7Ah
	15 minute Rate (7.92 A)	1.98Ah
Internal Resistance	Full charged Battery 77°F(25°C)	22mΩ
Capacity affected by Temperature (20 hour rate)	104°F(40°C)	102%
	77°F(25°C)	100%
	32°F(0°C)	85%
	5°F(-15°C)	65%
Self-Discharge 77°F(20°C)	Capacity after 3 month storage	91%
	Capacity after 6 month storage	81%
	Capacity after 12 month storage	60%
Max. Discharge Current 77°F(25°C)	67.5A(5S)	
Terminal	F1/F2	
Charge (Constant Voltage)	Cycle	Initial Charging Current less than 1.35A
		Voltage 14.4-14.7V/7°F(25°C)
	Float	Voltage 13.5-13.8V/77°F(25°C)

Relationship between charge voltage and temperature

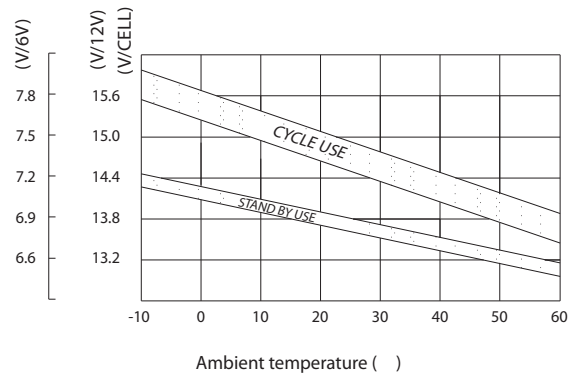

Constant Current Discharge (AMPERES @25°C)

F.V/Time	5Min	10Min	15Min	30Min	60Min	2H	3H	4H	5H	10H	20H
9.60	17.15	10.89	8.73	4.86	2.97	1.68	1.16	0.93	0.78	0.43	0.23
9.90	16.74	10.58	8.42	4.73	2.89	1.62	1.14	0.92	0.78	0.42	0.23
10.20	15.98	10.13	8.15	4.64	2.81	1.60	1.13	0.91	0.77	0.42	0.23
10.50	15.30	9.72	7.83	4.59	2.75	1.58	1.13	0.90	0.77	0.42	0.23
10.80	14.40	9.63	7.43	4.46	2.66	1.53	1.11	0.88	0.76	0.41	0.22

Constant Power Discharge (WATTS PER CELL@25°C)

F.V/Time	5Min	10Min	15Min	30Min	60Min	2H	3H	4H	5H	10H	20H
9.60	191.00	122.40	99.17	55.40	34.27	19.62	13.75	11.04	9.33	5.11	2.74
9.90	186.65	118.97	95.68	54.10	33.45	18.95	13.61	10.95	9.31	5.07	2.73
10.20	178.28	114.01	92.69	53.12	32.54	18.72	13.47	10.85	9.25	5.04	2.72
10.50	170.90	109.64	89.18	52.65	31.79	18.49	13.42	10.76	9.15	5.04	2.71
10.80	160.99	108.82	84.66	51.14	30.80	17.98	13.23	10.49	9.05	4.92	2.66

The operating environment temperature above 40°C should be avoided ,After long term storage, The battery actual capacity would be less than the rated capacity. Full capacity will be obtained through several charge/discharge cycles.
To get the longest life, KSTAR battery should be fully charged before storage.

Cycle service life in relation to depth of discharge

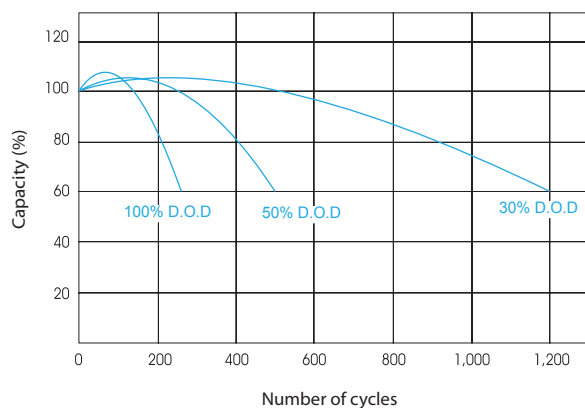

Constant voltage charge characteristic

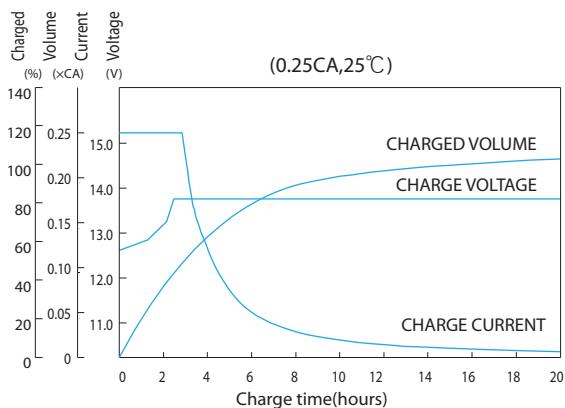

Self-Discharge Characteristics

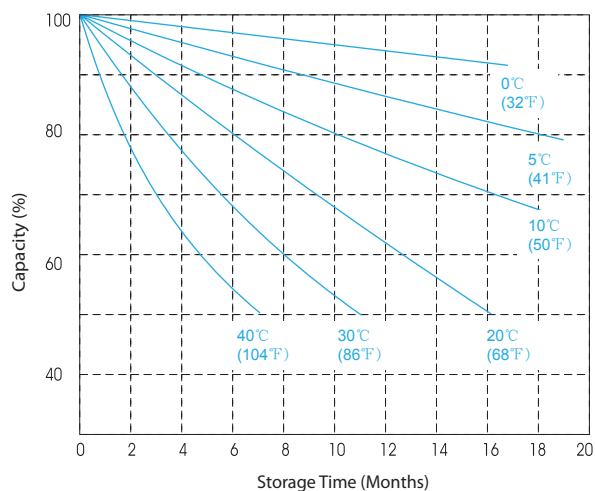

Relationship of OCV and Residual Capacity % (25°C)

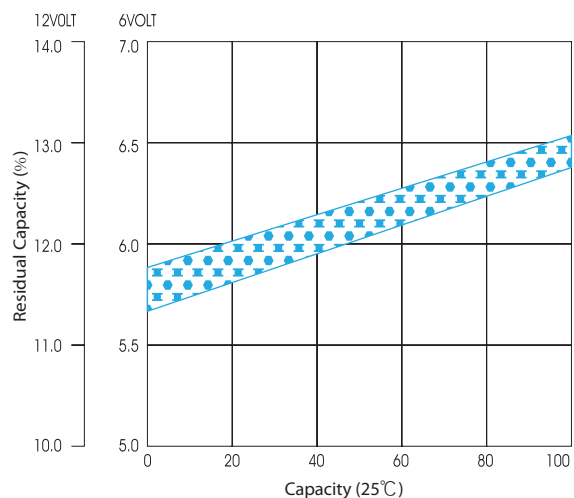

Temperature effects on capacity

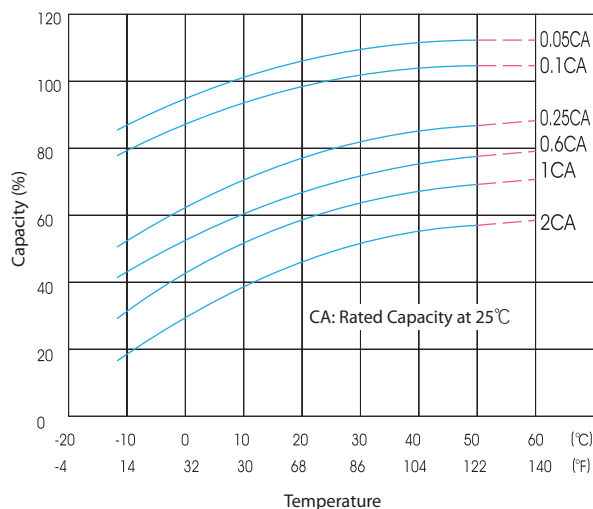

Temperature effects float life

